

Qi 15W Car Charger - C11



Instruction manual

Parameters Description

Product name: Wireless fast charging vehicle cradle (intelligent induction type)

Power: 15W/10W/7.5W

Effective transmission distance: 0-5mm

Boundary dimension: 111mm * 70mm * 46mm

Device size: 111mm* 60mm * 7.6mm

Charging interface: USB TYPE-C

Specifications

1. Weight: About 128g net weight.
2. Material: ABS / PC + glass panel + plastic
3. Executive standard: GB 4943.1-2011
4. Input voltage / current: DC5V/2A, DC9V1.67A
5. Wireless charging output power: 15W, 10W, 7.5W (automatic identification)
6. Charging power: 110K-205khz
7. Charging distance: 0-5mm
8. Supported specifications: Comply with Qi wireless charging protocol (including but not limited to the following cell phones).
9. Support QC wireless fast charging devices, such as iPhone X / iPhone8+, iPhone10 series, iPhone 11 series, iPhone 12 series, iPhone 12 series, iPhone 13 series, iPhone 14 series, Huawei P30 series, Mate20Pro, Mate30 series, Mate40 series, Samsung S6, S7, S8 series wireless charging module cell phones.
10. Devices that do not support wireless charging are connected to the magnetic head for use.

Functional components

(Note: devices that do not support wireless charging must be connected to the magnetic suction head.)

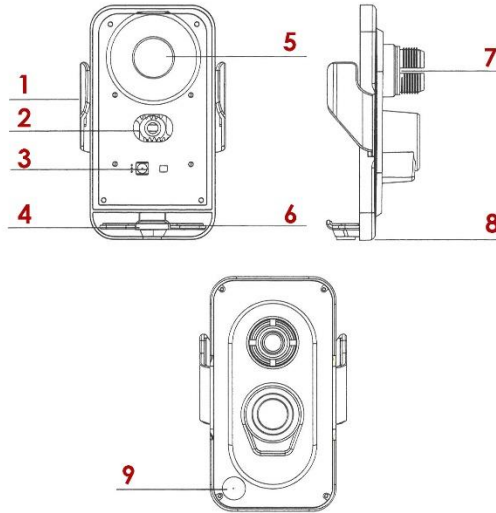

1. Automatic retractable clip
2. Mechanical equipment
3. Intelligent sensor area
4. Magnetic head contact point
5. Magnetic induction charging area
6. Lower support
7. Spherical base
8. USB / Type-C charging interface
9. Sensitive touch button.

Instructions for use

1. Connect the product to the appropriate data cable during use. 2.
2. Connect the USB end of the data cable to the vehicle interface (e.g. cigarette lighter converter and USB charging interface).
3. The base clamp attaches to the air outlet of the air conditioner, it can also be placed anywhere else where it can be securely attached.
4. After the equipment is connected to 5 - 9V DC power supply, it will automatically check the voltage and lock the bracket, the indicator light will be on.
5. When your cell phone comes within 5cm-20cm to the equipment, automatically the device will detect it and open the arms, place the cell phone, and the device will automatically adjust the clamps to hold it, at this time, the wireless fast charging will start the process of charging the cell phone (to cell phones that have wireless charging function).

6. To take out the cell phone, you have to touch the bottom right corner of the back, finger detection area, when your finger touches this position, the device will open automatically. The device has built-in over-voltage protection, over-temperature protection, magnetic field protection and short-circuit protection. In case of malfunction, it will automatically stop working.

Precautions

1. Do not overtighten the equipment or strike it.
2. Do not use in high temperature, humidity or corrosive environments. These environments may cause damage to the equipment circuitry.